

Bringing quality light  
to urban contexts  
with modular solutions  
inspired by nature.

# CELLS

Designed by SPEIRS MAJOR

Reggiani



**Reggiani**



# Contents

Intro	04
Cells	19



Garden Conservatory, Seoul



**EN** Designed by SPEIRS MAJOR and inspired by the cellular eye structure of a dragonfly, CELLS is an urban lighting solution designed to be installed as single or connected multiple modules.

**IT** Progettato dallo studio SPEIRS MAJOR e ispirato alla struttura oculare cellulare di una libellula, CELLS è una soluzione di illuminazione urbana progettata per essere installata a moduli singoli o in cluster.



# SPEIRS MAJOR

<sup>EN</sup> SPEIRS MAJOR is an independent, award-winning international lighting design practice. Over more than twenty-five years, SPEIRS MAJOR has completed hundreds of projects around the world ranging from lighting masterplans to pocket parks, major civic buildings to small community spaces; from airports and bridges to cathedrals and monuments. Through careful collaboration between a multidisciplinary design team, clients and design partners, SPEIRS MAJOR ensure that solutions are sustainable and easy to manage, balancing imagination with realism, passion with pragmatism.

<sup>IT</sup> SPEIRS MAJOR è uno studio di lighting design indipendente e pluripremiato a livello internazionale. In oltre venticinque anni, SPEIRS MAJOR ha completato centinaia di progetti in tutto il mondo, spaziando da piani regolatori per l'illuminazione a piccoli parchi, da grandi edifici civici a piccoli spazi comunitari; da aeroporti e ponti a cattedrali e monumenti. Attraverso una collaborazione attenta tra un team di progettazione multidisciplinare, clienti e partner di progetto, SPEIRS MAJOR garantisce soluzioni sostenibili e facili da gestire, bilanciando immaginazione con realismo, passione con pragmatismo.





EN "CELLS' advanced control optics give you a wide choice of functionality, from general illumination to bespoke configurations, making it ideal for both architectural and technical applications, indoors and out. The modules can be mounted on ceilings and walls, and you can choose from a wide range of finishes for different locations. We envisage our CELLS bringing light to an array of urban contexts, including exterior pathways, private and public facilities, parking lots and buildings." SPEIRS MAJOR

IT "L'ampia scelta di ottiche avanzate offre grande flessibilità funzionale: da un'illuminazione generale a configurazioni su misura e rende CELLS un prodotto ideale per applicazioni sia architettoniche che tecniche, sia interne che esterne. I moduli possono essere montati a soffitto e a parete, e si può scegliere tra una vasta gamma di finiture per diverse ambientazioni. Immaginiamo i nostri CELLS portare luce in una varietà di contesti urbani, tra cui percorsi esterni, strutture private e pubbliche, parcheggi ed edifici." SPEIRS MAJOR







ELLI, Residential Building and Studio, Zurigo





<sup>EN</sup> IK10 shock resistant diffuser  
<sup>IT</sup> Diffusore resistente ai colpi (IK10)



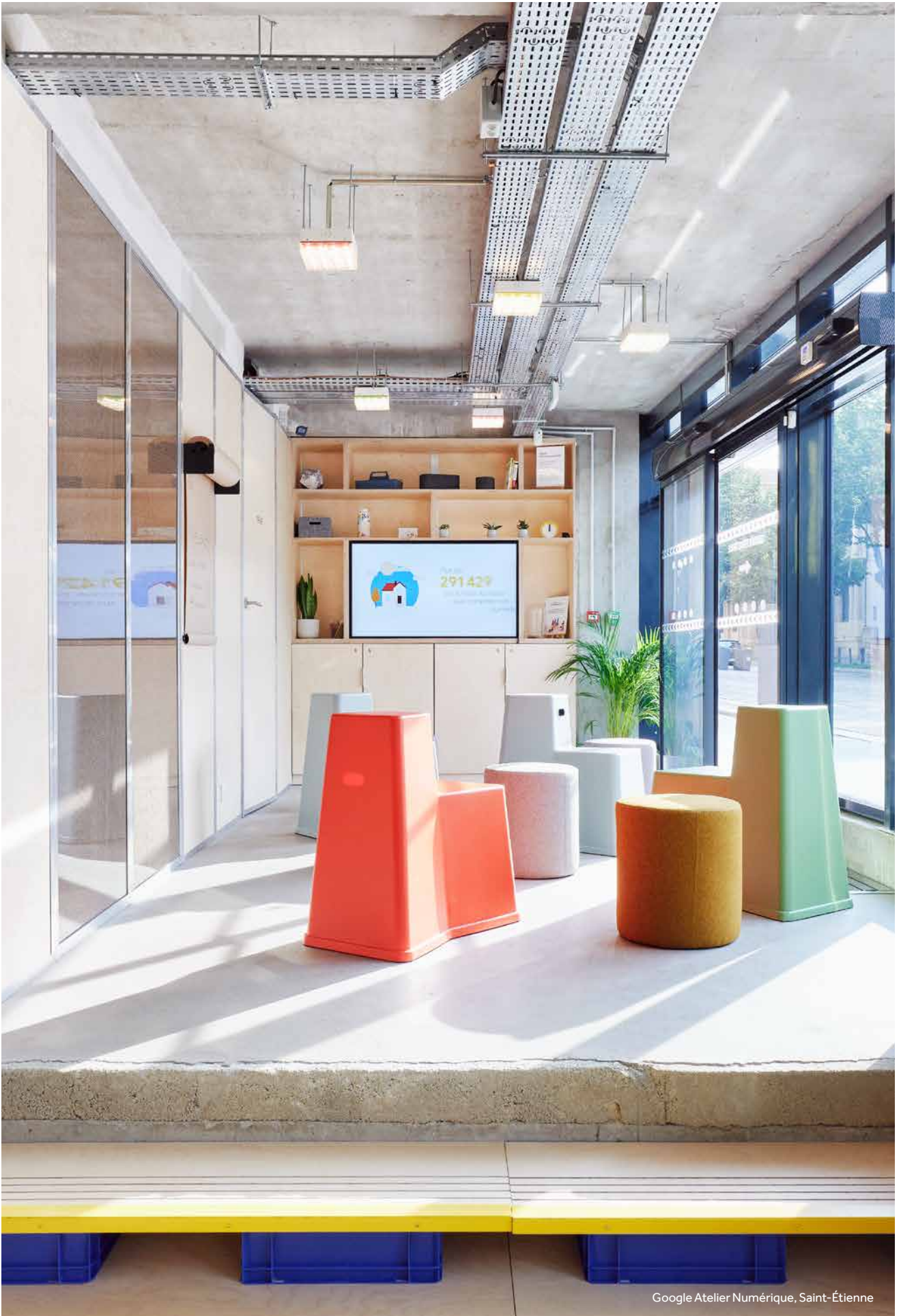

Google Atelier Numérique, Saint-Étienne



ELLI Residential Building and Studio, Zurigo



Garden Conservatory, Seoul





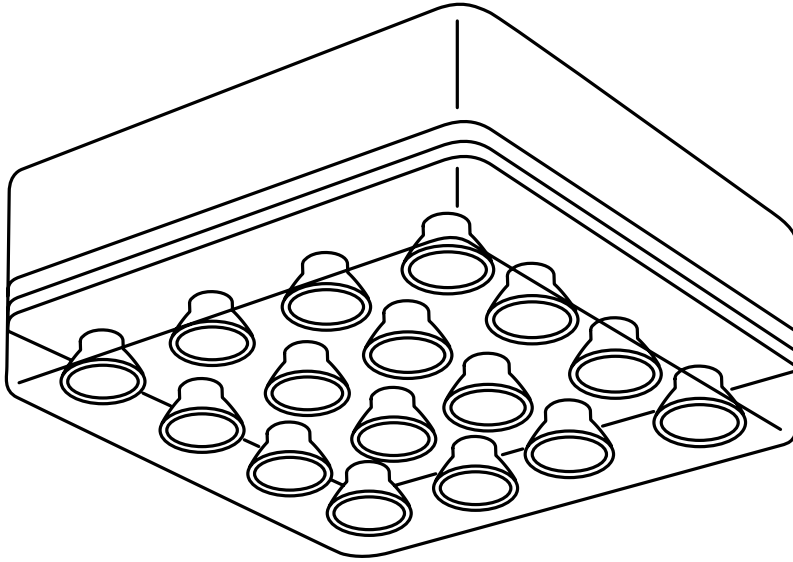













# Cells



EN A range of exterior luminaires IP66 and IK10 suitable for installation in ceilings or walls. These high performance luminaires blend in perfectly with the architectural context thanks to the many aesthetic options available. The advanced optics control system makes it possible to select options for general lighting or bespoke configurations and applications.

IT Una gamma di apparecchi da esterni IP66 e IK10 per l'installazione a soffitto o a parete, in grado di fornire performance eccellenti e di integrarsi perfettamente nel contesto architettonico grazie alle diverse variabili estetiche. L'avanzato sistema di controllo del fascio consente di scegliere tra soluzioni per l'illuminazione generale o per specifiche applicazioni.



Versions/ Versioni	
Cells	<div style="display: flex; justify-content: space-around; align-items: center;"> <div style="text-align: center;">  <p>Transparent</p> </div> <div style="text-align: center;">  <p>Opal</p> </div> </div>
Finishes/ Finiture	<p><b>Body</b></p> <div style="display: flex; justify-content: space-around; align-items: center;"> <div style="text-align: center;">  <p><b>Q/48</b> White/ Bianco</p> </div> <div style="text-align: center;">  <p><b>R/08</b> Graphite/ Grafite</p> </div> <div style="text-align: center;">  <p><b>S/28</b> Gray/ Grigio</p> </div> <div style="text-align: center;">  <p><b>V/98</b> Raw aluminium/ Alluminio grezzo</p> </div> </div> <p><b>Plates</b></p> <div style="display: flex; justify-content: space-around; align-items: center;"> <div style="text-align: center;">  <p><b>0</b> White/ Bianco</p> </div> <div style="text-align: center;">  <p><b>1</b> Chrome/ Cromatico</p> </div> <div style="text-align: center;">  <p><b>2</b> Gray/ Grigio</p> </div> <div style="text-align: center;">  <p><b>8</b> Graphite/ Grafite</p> </div> </div> <p><b>Colored plates (on request)</b></p> <div style="display: flex; justify-content: space-around; align-items: center;"> <div style="text-align: center;">  <p>Yellow/ Giallo</p> </div> <div style="text-align: center;">  <p>Red/ Rosso</p> </div> <div style="text-align: center;">  <p>Blue/ Blu</p> </div> <div style="text-align: center;">  <p>Green/ Verde</p> </div> </div>
Color temperature	3000 K. On request: 4000K, Tunable White
IP	66
IK	10
Control systems	On/Off, DALI, Emergency. On request: Bluetooth
Certifications	  

Choose the diffuser

Choose the optics

Choose the plate

Choose the body

Choose your Cells



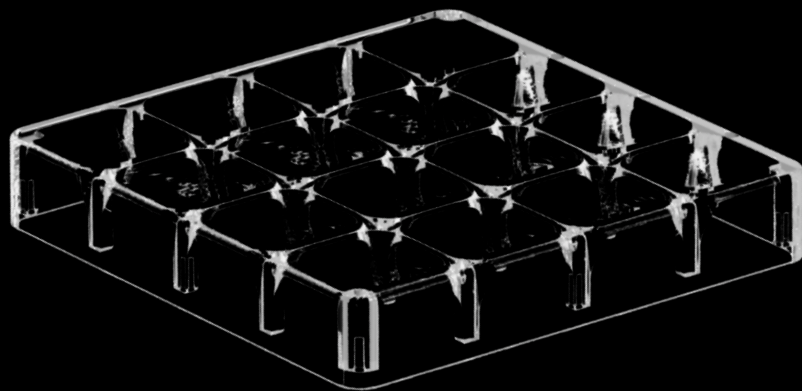

## IK 10 Diffuser

- Transparent/Trasparente
- Opal/Opale



## Optics

- E Medium/Medio
- M Wide/Largo
- O Very wide/Molto largo
- U Rectangular/Rettangolare
- S Asymmetric/Asimetrico
- T Double asymmetric/Doppio asimmetrico

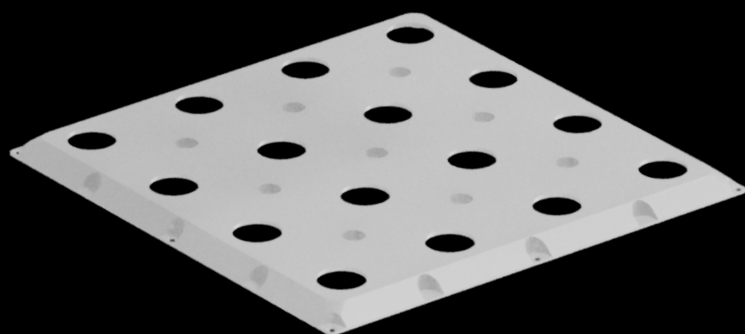

## Plates

- 0 White/Bianco
- 1 Chrome/Cromato
- 2 Grey/Grigio
- 8 Graphite/Grafite

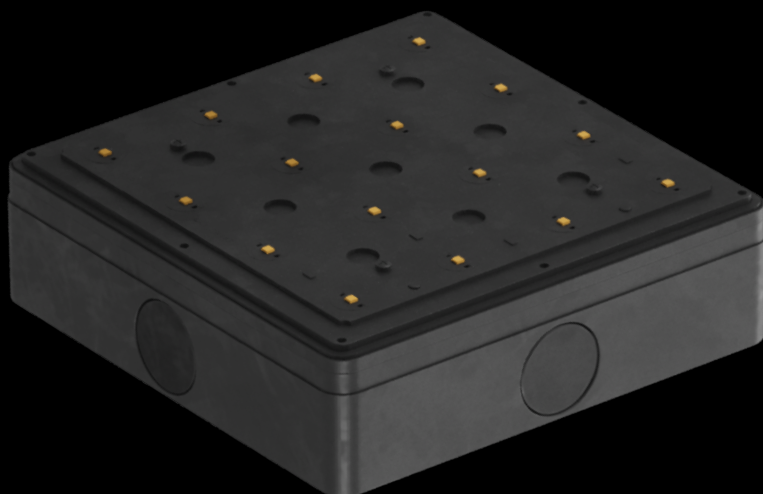

## Body

- Q/48 White/Bianco
- R/08 Graphite/Grafite
- S/28 Grey/Grigio
- V/98 Raw aluminium/Alluminio grezzo

# Transparent diffuser

EN Choose the transparent diffuser to get the most from all the CELLS optics alternatives: medium, wide, very wide, rectangular, asymmetric and double asymmetric. Customize the product choosing between bodies and plates.

IT Scegli il diffusore trasparente e sfrutta al meglio tutte le alternative ottiche disponibili per CELLS: fascio medio, largo, molto largo, rettangolare, asimmetrico e doppio asimmetrico. Personalizza il prodotto scegliendo tra diversi i body e plates.



## Body



EN White  
IT Bianco



EN Raw aluminium  
IT Alluminio grezzo



EN Grey  
IT Grigio



EN Graphite  
IT Grafite

## Plates



EN White  
IT Bianco



EN Chrome  
IT Cromatico



EN Grey  
IT Grigio



EN Graphite  
IT Grafite

## Optics



EN Medium  
IT Medio



EN Wide  
IT Largo



EN Very wide  
IT Molto largo



EN Rectangular  
IT Rettangolare



EN Asymmetric  
IT Asimetrico



EN Double asymmetric  
IT Doppio asimmetrico



Reggiani L&B booth

Examples

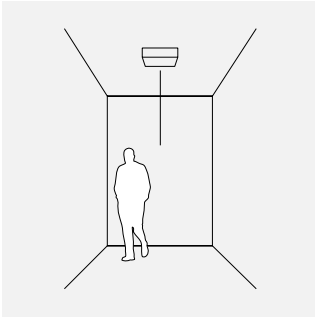

EN Optics: Medium, wide.  
IT Ottica: Medio, largo.

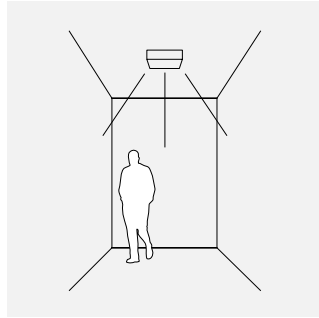

EN Optics: Rectangular or very wide.  
IT Ottica: Rettangolare o molto largo.

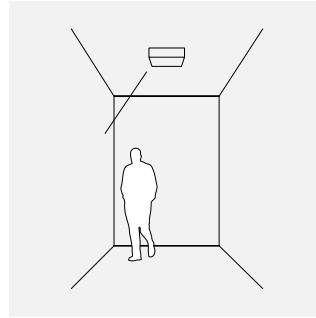

EN Optics: Asymmetric  
IT Ottica: Asimmetrico.

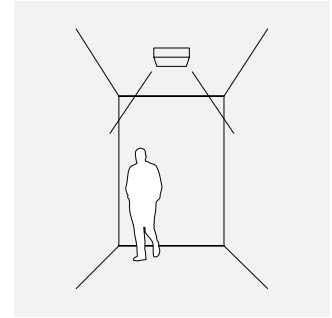

EN Optics: Double asymmetric.  
IT Ottica: Doppio asimmetrico.

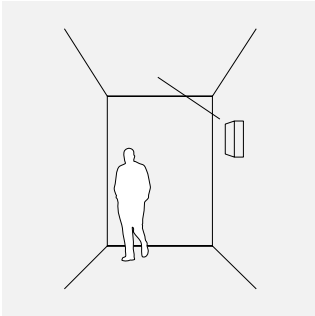

EN Optics: Asymmetric.  
IT Ottica: Asimmetrico.

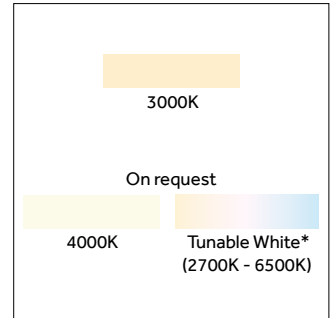

EN \*For medium, wide and very wide beam.  
IT \* Per fascio medium, largo e molto largo.

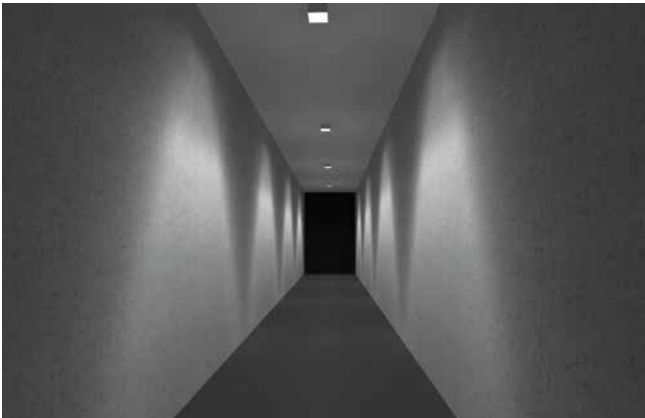

EN Optics: Double asymmetric  
IT Ottica: Doppio asimmetrico



EN Optics: Rectangular or very wide.  
IT Ottica: Rettangolare o molto largo.

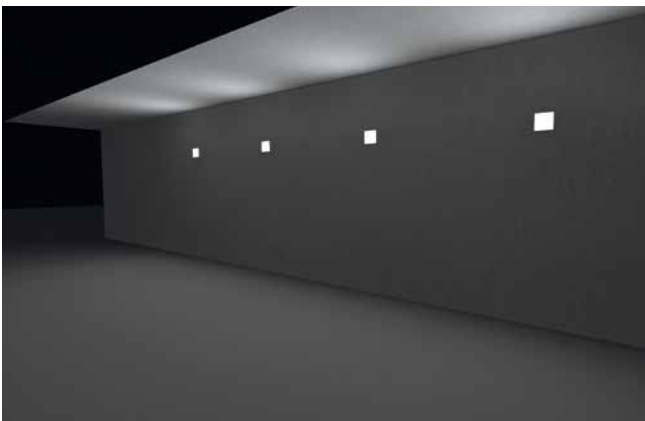

EN Optics: Asymmetric.  
IT Ottica: Asimmetrico.

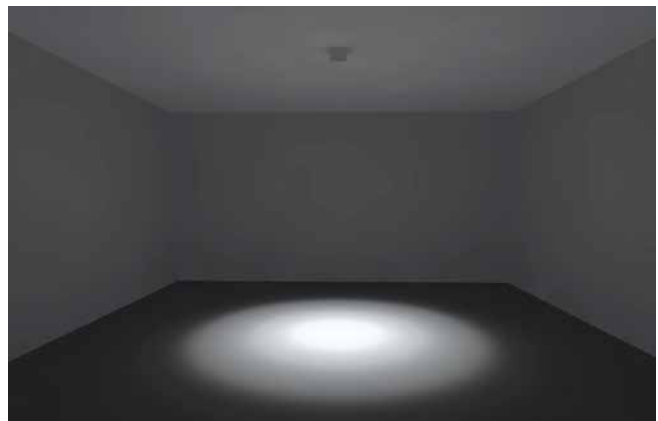

EN Optics: Medium, wide.  
IT Ottica: Medio, Largo.

# Opal diffuser

EN Choose the opal diffuser for a very wide and diffusive lighting effect and customize the product choosing between four different bodies.

IT Scegli il diffusore opale per un effetto di luce diffusa a fascio molto largo. Personalizza il prodotto scegliendo tra quattro diversi body.



## Body



EN White  
IT Bianco



EN Raw aluminium  
IT Alluminio grezzo



EN Grey  
IT Grigio



EN Graphite  
IT Grafite

## Plate



EN White  
IT Bianco

## Optics



EN Very wide  
IT Molto largo

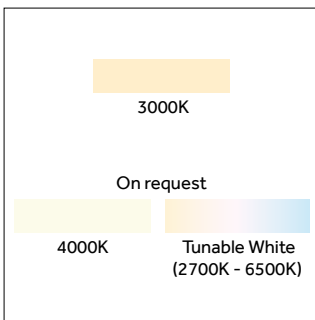

EN LED Colour temperatures  
IT Temperature colore LED

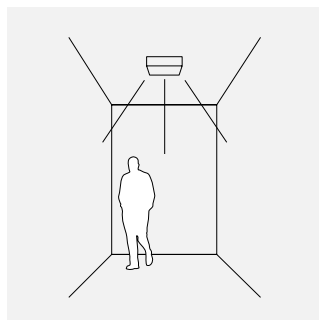

EN Optics: Very wide.  
IT Ottica: Molto largo.

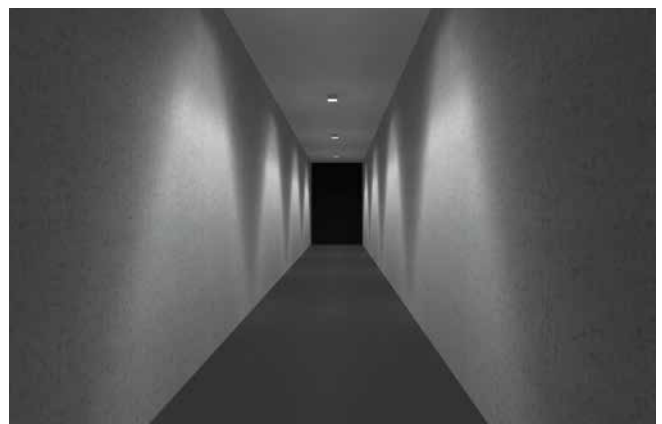

EN Optics: very wide.  
IT Ottica: molto largo.

# Create your own Cells layout

EN CELLS modules can be joined together using a connector available as an accessory to create more complex lighting configurations. Anti-glare accessories and adjustable brackets further increase the flexibility of the product and its use in different environments. Create your own CELLS layout.

IT I moduli CELLS possono essere uniti tra loro tramite un connettore disponibile come accessorio per creare configurazioni di illuminazione più complesse. Gli accessori antiabbagliamento e le staffe orientabili aumentano ulteriormente la flessibilità del prodotto e le sue possibilità di utilizzo in diversi ambienti. Dai forma al tuo layout CELLS.



EN Connector  
IT Connettore



EN Visor  
IT Visiera



EN 90° adjustable bracket  
IT Staffa per orientamento 90°





Reggiani L&B booth



# Colored plates

On request

Cells

EN On request, CELLS is also available with colored plates. The warmth of yellow, the energy of red, the tranquility of blue, or the freshness of green: combine these colors to create your personalized CELLS.

IT Su richiesta, CELLS è disponibile anche con plate colorate. Il calore del giallo, l'energia del rosso, la tranquillità del blu o la freschezza del verde: abbina questi colori per creare i tuoi CELLS personalizzati.

## Colored plates



EN Yellow  
IT Giallo



EN Blue  
IT Blu





EN Red  
IT Rosso

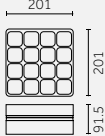
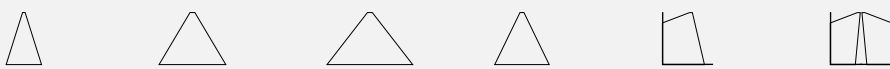

EN Green  
IT Verde

# Technical info & codes

<b>Surface</b>	 <p>p.36-37</p>																							
<b>Beams/ Fasci</b>	 <table border="1" data-bbox="454 705 1457 772"> <thead> <tr> <th>Medium/ Medio</th> <th>Wide/ Largo</th> <th>Very Wide/ Molto Largo</th> <th>Rectangular/ Rettangolare</th> <th>Asymmetric/ Asimmetrico</th> <th>Double Asymmetric/ Doppio Asimmetrico</th> </tr> </thead> <tbody> <tr> <td>24°</td> <td>55°</td> <td>68°</td> <td>56°+34°</td> <td>43°+61°</td> <td>86°+64°</td> </tr> <tr> <td>-</td> <td>-</td> <td>81°</td> <td>-</td> <td>-</td> <td>-</td> </tr> </tbody> </table>						Medium/ Medio	Wide/ Largo	Very Wide/ Molto Largo	Rectangular/ Rettangolare	Asymmetric/ Asimmetrico	Double Asymmetric/ Doppio Asimmetrico	24°	55°	68°	56°+34°	43°+61°	86°+64°	-	-	81°	-	-	-
Medium/ Medio	Wide/ Largo	Very Wide/ Molto Largo	Rectangular/ Rettangolare	Asymmetric/ Asimmetrico	Double Asymmetric/ Doppio Asimmetrico																			
24°	55°	68°	56°+34°	43°+61°	86°+64°																			
-	-	81°	-	-	-																			
 Transparent diffuser Opal diffuser	24°	55°	68°	56°+34°	43°+61°	86°+64°																		
<b>Light source/ Sorgente luminosa</b>	<p><b>LEDARRAY</b> 13 W; 18 W 2096 lm-2560 lm L70 B50=50,000h 3000K, CRI &gt;80 SDCM &lt;3</p> <p><b>On request:</b> 4000K, CRI &gt;80</p> <p> <b>Tunable white</b> 2700 K-6500K</p>																							

## Transparent diffuser/Diffusore trasparente

Risk 0 2.10 IK10 IP66 850°

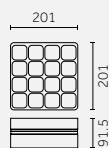

Code example:

0 . BG03 E . WW Q 0

Accessories: p.38

## Notes:

- In chart nominal Lumen/In tabella Lumen nominali.

- Version 13W: for environments up to 50°C/Versione 13W: per ambienti fino a 50°C.

\*\* 3 hours emergency - When operating in emergency mode, luminous flux is 30% of the lumens emitted under normal operating conditions/  
 \*\*Versione emergenza 3 ore - Il prodotto in funzionamento di emergenza emette il 30% del flusso emesso in condizioni standard.

## Photometric data:

www.reggiani.net

**13 W LED ARRAY** Lumen delivered up to 1474 lm / Lumen maintenance: L70 B50=50,000h

Driver	Version	Optics	LED	K	CRI	lm	SDCM	Body	Plates	
0 On/Off	BG03	E 24° Medium*	WW	3000	>80	2096	<3	Q	0	
D DALI		M 55° Wide*	On request:						R	1
On request		0 68° Very wide*	4000K (CRI >80)						S	2
H Bluetooth		U 56°+34° Rectangular	Tunable white: (2700K-6500K)*						V	8
		S 43°+61° Asymmetric								
	T 86°+64° Double asymmetric									

**13 W Emergency\*\* LED ARRAY** Lumen delivered up to 1474 lm / Lumen maintenance: L70 B50=50,000h

Driver	Version	Optics	LED	K	CRI	lm	SDCM	Body	Plates	
0 On/Off	MG03	E 24° Medium*	WW	3000	>80	2096	<3	Q	0	
D DALI		M 55° Wide*	On request:						R	1
		0 68° Very wide*	4000K (CRI >80)						S	2
		U 56°+34° Rectangular							V	8
		S 43°+61° Asymmetric								
	T 86°+64° Double asymmetric									

**18 W LED ARRAY** Lumen delivered up to 1800 lm / Lumen maintenance: L70 B50=50,000h

Driver	Version	Optics	LED	K	CRI	lm	SDCM	Body	Plates	
0 On/Off	BG04	E 24° Medium*	WW	3000	>80	2560	<3	Q	0	
D DALI		M 55° Wide*	On request:						R	1
On request		0 68° Very wide*	4000K (CRI >80)						S	2
H Bluetooth		U 56°+34° Rectangular	Tunable white: (2700K-6500K)*						V	8
		S 43°+61° Asymmetric								
	T 86°+64° Double asymmetric									

**18 W Emergency\*\* LED ARRAY** Lumen delivered up to 1800 lm / Lumen maintenance: L70 B50=50,000h

Driver	Version	Optics	LED	K	CRI	lm	SDCM	Body	Plates	
0 On/Off	MG04	E 24° Medium*	WW	3000	>80	2560	<3	Q	0	
D DALI		M 55° Wide*	On request:						R	1
		0 68° Very wide*	4000K (CRI >80)						S	2
		U 56°+34° Rectangular							V	8
		S 43°+61° Asymmetric								
	T 86°+64° Double asymmetric									

## Finishes / Finiture

## Body

- Q White/Bianco
- R Graphite/Grafite
- S Grey/Grigio
- V Raw aluminium/Alluminio grezzo

## Plates

- 0 White/Bianco
- 1 Chrome/Cromato
- 2 Grey/Grigio
- 8 Graphite/Grafite

# Opal diffuser/Diffusore Opale

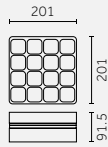

Code example:

**0** - **CG03** **0** - **WW 48**

Accessories: p.38

**Notes:**

- In chart nominal Lumen/ In tabella Lumen nominali.  
 - Version 13W: for environments up to 50 °C/ Versione 13 W: per ambienti fino a 50 °C.

\*3 hours emergency - When operating in emergency mode, luminous flux is 30% of the lumens emitted under normal operating conditions/

\*Versione emergenza 3 ore - Il prodotto in funzionamento di emergenza emette il 30% del flusso emesso in condizioni standard.

Photometric data:  
[www.reggiani.net](http://www.reggiani.net)

**13 W LED ARRAY** Lumen delivered up to 1015 lm / Lumen maintenance: L70 B50=50,000h

Driver	Version	Optics	LED	K	CRI	lm	SDCM	Body	Plates
<b>0</b> On/Off	<b>CG03</b>	<b>0</b> 81° Very wide	<b>WW</b>	3000	>80	2096	<3	<b>48</b>	White plate only
<b>D</b> DALI								<b>08</b>	
<b>Onrequest</b>								<b>28</b>	
<b>H</b> Bluetooth								<b>98</b>	

Onrequest: 4000K (CRI >80)  
 Tunable white: (2700K-6500K)

**13 W Emergency\* LED ARRAY** Lumen delivered up to 1015 lm / Lumen maintenance: L70 B50=50,000h

Driver	Version	Optics	LED	K	CRI	lm	SDCM	Body	Plates
<b>0</b> On/Off	<b>NG03</b>	<b>0</b> 81° Very wide	<b>WW</b>	3000	>80	2096	<3	<b>48</b>	White plate only
<b>D</b> DALI								<b>08</b>	
								<b>28</b>	
								<b>98</b>	

4000K (CRI >80)

**18 W LED ARRAY** Lumen delivered up to 1240 lm / Lumen maintenance: L70 B50=50,000h

Driver	Version	Optics	LED	K	CRI	lm	SDCM	Body	Plates
<b>0</b> On/Off	<b>CG04</b>	<b>0</b> 81° Very wide	<b>WW</b>	3000	>80	2560	<3	<b>48</b>	White plate only
<b>D</b> DALI								<b>08</b>	
<b>Onrequest</b>								<b>28</b>	
<b>H</b> Bluetooth								<b>98</b>	

Onrequest: 4000K (CRI >80)  
 Tunable white: (2700K-6500K)

**18 W Emergency\* LED ARRAY** Lumen delivered up to 1240 lm / Lumen maintenance: L70 B50=50,000h

Driver	Version	Optics	LED	K	CRI	lm	SDCM	Body	Plates
<b>0</b> On/Off	<b>NG04</b>	<b>0</b> 81° Very wide	<b>WW</b>	3000	>80	2560	<3	<b>48</b>	White plate only
<b>D</b> DALI								<b>08</b>	
								<b>28</b>	
								<b>98</b>	

4000K (CRI >80)

**Finishes / Finiture**

**Body**

- 48** White/Bianco
- 08** Graphite/Grafite
- 28** Grey/Grigio
- 98** Raw aluminium/Alluminio grezzo

# Accessories

## Mounting accessories/ Accessori montaggio

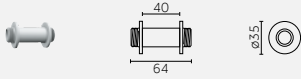

### Description

Connector/  
Connettore

### Code

0.26030.00

### Finishes

48  
08  
28  
98

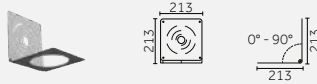

### Description

90° adjustable bracket/  
Staffa per orientamento 90°

### Code

0.26111.00

### Finishes

48  
08  
28  
00

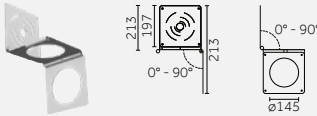

### Description

90° two axis adjustable bracket/  
Staffa per doppio orientamento 90°

### Code

0.26112.00

### Finishes

48  
08  
28  
00

## Cells accessories/ Accessori Cells

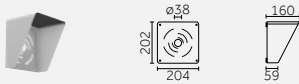

### Description

Visor/  
Visiera

### Code

0.26110.00

### Finishes

48  
08  
28  
00





# Reggiani

©  
2024  
Reggiani Lighting S.r.l  
All rights reserved

<sup>EN</sup> Reggiani Lighting Srl reserves the right to make technical, design and size changes at any time, without prior notice. Total or partial reproduction of this document is prohibited. Luminaire sizes are given in millimetres. All technical and design innovations are patented. Watts and lumens refer to the nominal values of the LED source; for photometric data and lumen output of the luminaires, visit [www.reggiani.net](http://www.reggiani.net)

<sup>IT</sup> Reggiani Lighting Srl si riserva la facoltà di effettuare in qualsiasi momento senza preavviso, variazioni tecniche, formali e dimensionali. Sono vietate le riproduzioni anche parziali del presente documento. Le dimensioni degli apparecchi sono espresse in millimetri. Tutte le innovazioni tecniche e formali sono coperte da brevetto. Watt e lumen fanno riferimento ai valori nominali della sorgente LED, per i dati fotometrici e il lumen output degli apparecchi visitare [www.reggiani.net](http://www.reggiani.net)

**HEADQUARTERS**  
Reggiani Lighting Srl

Viale Monza 16  
20845 Sovico (MB), Italy  
T. (+39) 039 20711

**Art direction**  
Reggiani

**Graphic design**  
Reggiani

**Pictures**  
Rohspace (p.4, 17)  
Radek Brunecky (p.12, 16)  
Marco Reggi (p.13, 26, 31)  
David Foessel (p. 15)



Part of  
**NEMO Group**



